

No attempt has been made to rank the information contained in this report in order of importance, since BPA Worldwide believes this is a judgment, which must be made by the user of the report.

100 Beard Sawmill Road, Sixth Floor
Shelton, CT USA 06484-6150
Phone: +1 203.447.2800
Fax: +1 203.447.2900
www.bpaww.com

A not-for-profit organization since 1931, BPA Worldwide is governed by a tripartite board comprised of media owners, advertising agencies and advertisers. Headquartered in Shelton, Connecticut, USA, BPA has the largest membership of any media-auditing organization in the world, spanning more than 30 countries. Worldwide, BPA audits 2,600+ media properties—including over 1,500 B-to-B publications, more than 350 consumer magazines, 150 newspapers, 550+ web sites, 40 events, email newsletters, databases, wireless and other advertiser-supported media—as well as 2,700 advertiser and agency members.

Visit www.bpaww.com for the latest audit reports, membership information and publishing and advertising industry news.



A Penton Media Publication

Penton Media, Inc.
1300 East 9th Street
Cleveland, OH 44114
Tel. No.: 216-696-7000
FAX No.: 216-931-9616
www.medicaldesign.com

Official Publication of: None
Established: 2001
Issues per Year: 10



FIELD SERVED

MEDICAL DESIGN serves companies and individuals involved in the manufacturing of finished medical devices, manufacturing of in-vitro diagnostics, manufacturing of pharmaceuticals, manufacturing service provider, manufacturing consultants, government/academic and others allied to the field.

DEFINITION OF RECIPIENT QUALIFICATION

Qualified recipients are those industry personnel who perform the following job functions: design engineering, design engineering management, manufacturing/production management, research & development, general/corporate executive, marketing & finance, quality assurance & quality control, regulatory affairs and others allied to the field (including consulting and other functions not available).

AVERAGE NON-QUALIFIED CIRCULATION

NON-QUALIFIED Not Included Elsewhere	Copies
Other Paid Circulation _____	15
Advertiser and Agency _____	2,434
Rotated or Occasional _____	-
Allocated for Trade Shows and Conventions _____	90
Digital _____	-
All Other _____	-
TOTAL	2,539

1. AVERAGE QUALIFIED CIRCULATION BREAKOUT FOR PERIOD

QUALIFIED CIRCULATION	Total Qualified		Qualified Non-Paid		Qualified Paid	
	Copies	Percent	Copies	Percent	Copies	Percent
Individual _____	34,829	100.0	34,829	100.0	-	-
Sponsored Individually Addressed _____	-	-	-	-	-	-
Membership Benefit _____	-	-	-	-	-	-
Multi-Copy Same Addressee _____	-	-	-	-	-	-
Single Copy Sales _____	-	-	-	-	-	-
TOTAL QUALIFIED CIRCULATION	34,829	100.0	34,829	100.0	-	-

2. QUALIFIED CIRCULATION BY ISSUES FOR PERIOD

2011 Issue	Number Removed	Number Added	Print Version Only (A)	Digital Version Only (B)	Total Qualified
January/February _____	192	115	29,099	5,917	35,016
March _____	33	77	29,125	5,757	34,882
April _____	183	224	29,121	5,682	34,803
May _____	188	185	29,108	5,644	34,752
June _____	38	47	29,105	5,587	34,692
TOTAL	634	648			

3a. BUSINESS/OCCUPATION BREAKOUT OF QUALIFIED CIRCULATION FOR ISSUE OF MAY 2011
This issue is 0.3% or 96 copies below the average of the other 4 issues reported in Paragraph two.

Business & Industry	TOTAL QUALIFIED	PERCENT OF TOTAL	Print Version Only (A)	Digital Version Only (B)	Design Engineering	Design Engineering Mgmt	Manufacturing, Production Mgmt	Research & Development	General/Corporate Mgmt	Quality Assurance & Quality Control	Regulatory Affairs	Other Functions (Note 1)
Manufacturer of Finished Medical Devices/ Manufacturing Services Provider _____	22,116	63.6	18,284	3,832	5,742	2,071	2,803	2,819	6,074	1,697	346	564
Manufacturer of InVitro Diagnostics _____	795	2.3	617	178	168	68	89	172	179	84	16	19
Manufacturer of Pharmaceuticals _____	2,018	5.8	1,596	422	258	94	333	459	478	275	70	51
Manufacturing Consultant _____	2,769	8.0	2,176	593	875	310	118	424	698	219	48	77
Government/Academic _____	2,223	6.4	1,647	576	419	140	73	684	356	371	57	123
Others Allied to the Field Served _____	4,831	13.9	4,788	43	1,558	1,385	60	641	420	383	52	332
TOTAL QUALIFIED CIRCULATION	34,752	100.0	29,108	5,644	9,020	4,068	3,476	5,199	8,205	3,029	589	1,166
PERCENT	100.0		83.8	16.2	26.0	11.7	10.0	15.0	23.6	8.7	1.7	3.3

Note 1: Other Functions include consulting, marketing & finance management and other functions not available

3a. Breakout of Qualified Circulation of Business and Industry Area of Employment

BUSINESS AND INDUSTRY	TOTAL QUALIFIED	PERCENT OF TOTAL
A Manufacturer of Finished Medical Devices/Manufacturing Services Provider _____	22,116	63.6
B Manufacturer of InVitro Diagnostics _____	795	2.3
C Manufacturer of Pharmaceuticals _____	2,018	5.8
D Manufacturing Consultant _____	2,769	8.0
E Government/Academic _____	2,223	6.4
F Others Allied to the Field Served _____	4,831	13.9

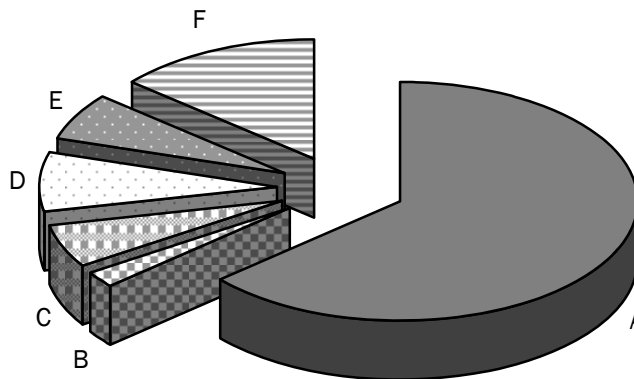

3b. QUALIFICATION SOURCE BREAKOUT OF QUALIFIED CIRCULATION FOR ISSUE OF MAY 2011							
QUALIFICATION SOURCE	Qualified Within			Print Version Only (A)	Digital Version Only (B)	Total Qualified	Percent
	1 Year	2 Years	3 Years				
I. Direct Request: _____	23,362	7,928	-	25,646	5,644	31,290	90.0
II. Request from recipient's company: _____	-	-	-	-	-	-	-
III. Membership Benefit: _____	-	-	-	-	-	-	-
IV. *Communication from recipient or recipient's company (other than request): _____	3,462	-	-	3,462	-	3,462	10.0
V. TOTAL - Sources other than above (listed alphabetically): _____	-	-	-	-	-	-	-
Association rosters and directories _____	-	-	-	-	-	-	-
Business directories _____	-	-	-	-	-	-	-
Manufacturer's, distributor's, and wholesaler's lists _____	-	-	-	-	-	-	-
Other sources _____	-	-	-	-	-	-	-
VI. Single Copy Sales: _____	-	-	-	-	-	-	-
TOTAL QUALIFIED CIRCULATION	26,824	7,928	-	29,108	5,644	34,752	100.0
PERCENT	77.2	22.8	-	83.8	16.2	100.0	

*See Additional Data

3c. MAILING ADDRESS BREAKOUT OF QUALIFIED CIRCULATION FOR ISSUE OF MAY 2011				
MAILING ADDRESS	Print Version Only (A)	Digital Version Only (B)	Total Qualified	Percent
Individuals by name and title and/or function _____	29,108	5,644	34,752	100.0
Individuals by name only _____	-	-	-	-
Titles or functions only _____	-	-	-	-
Company names only _____	-	-	-	-
Multi-Copy Same Addressee copies _____	-	-	-	-
Single Copy Sales _____	-	-	-	-
TOTAL QUALIFIED CIRCULATION	29,108	5,644	34,752	100.0

4. GEOGRAPHICAL BREAKOUT OF QUALIFIED CIRCULATION FOR ISSUE OF MAY 2011									
State	Print Version Only (A)	Digital Version Only (B)	Total Qualified	Percent	State	Print Version Only (A)	Digital Version Only (B)	Total Qualified	Percent
Maine _____	89	17	106		Kentucky _____	232	36	268	
New Hampshire _____	285	52	337		Tennessee _____	461	95	556	
Vermont _____	81	15	96		Alabama _____	245	36	281	
Massachusetts _____	1,577	368	1,945		Mississippi _____	124	17	141	
Rhode Island _____	139	25	164		EAST SO. CENTRAL	1,062	184	1,246	3.6
Connecticut _____	762	130	892		Arkansas _____	139	19	158	
NEW ENGLAND	2,933	607	3,540	10.2	Louisiana _____	116	24	140	
New York _____	1,779	310	2,089		Oklahoma _____	177	28	205	
New Jersey _____	1,221	245	1,466		Texas _____	1,266	281	1,547	
Pennsylvania _____	1,823	330	2,153		WEST SO. CENTRAL	1,698	352	2,050	5.9
MIDDLE ATLANTIC	4,823	885	5,708	16.4	Montana _____	47	9	56	
Ohio _____	1,592	280	1,872		Idaho _____	90	15	105	
Indiana _____	890	171	1,061		Wyoming _____	21	4	25	
Illinois _____	1,613	294	1,907		Colorado _____	439	92	531	
Michigan _____	863	203	1,066		New Mexico _____	70	26	96	
Wisconsin _____	914	164	1,078		Arizona _____	303	90	393	
EAST NO. CENTRAL	5,872	1,112	6,984	20.1	Utah _____	342	83	425	
Minnesota _____	1,310	332	1,642		Nevada _____	90	26	116	
Iowa _____	218	46	264		MOUNTAIN	1,402	345	1,747	5.0
Missouri _____	513	86	599		Alaska _____	7	-	7	
North Dakota _____	40	8	48		Washington _____	443	100	543	
South Dakota _____	58	14	72		Oregon _____	337	63	400	
Nebraska _____	213	37	250		California _____	3,618	556	4,174	
Kansas _____	228	30	258		Hawaii _____	8	2	10	
WEST NO. CENTRAL	2,580	553	3,133	9.0	PACIFIC	4,413	721	5,134	14.8
Delaware _____	103	24	127		UNITED STATES	28,553	5,510	34,063	98.0
Maryland _____	428	106	534		U.S. Territories _____	42	17	59	
Washington, DC _____	20	6	26		Canada _____	512	117	629	
Virginia _____	410	71	481		Mexico _____	-	-	-	
West Virginia _____	91	19	110		Other International _____	-	-	-	
North Carolina _____	705	146	851		APO/FPO _____	1	-	1	
South Carolina _____	295	37	332		TOTAL QUALIFIED CIRCULATION	29,108	5,644	34,752	100.0
Georgia _____	489	90	579						
Florida _____	1,229	252	1,481						
SOUTH ATLANTIC	3,770	751	4,521	13.0					

AVERAGE ANNUAL AUDITED QUALIFIED CIRCULATION AND CURRENT UNAUDITED CIRCULATION STATEMENTS

6-Month Period Ended:	Audited Data	Audited Data	Audited Data	Audited Data	Audited Data	Circulation Claim
	July-December 2008	January-June 2009	July-December 2009	January-June 2010	July-December 2010	January-June 2011*
Total Audit Average Qualified	40,336	35,664	34,958	35,062	35,099	34,829
Qualified Non-Paid Total	40,336	35,664	34,958	35,062	35,099	34,829
Print Version Only	38,188	33,662	31,744	31,066	29,913	29,112
Digital Version Only	2,148	2,002	3,214	3,996	5,186	5,717
Qualified Paid Total	-	-	-	-	-	-
Print Version Only	-	-	-	-	-	-
Digital Version Only	-	-	-	-	-	-
Post Expire Copies included in Total Qualified Circulation	**NC	**NC	**NC	**NC	**NC	**NC
Average Annual Order Price	**NC	**NC	**NC	**NC	**NC	**NC

*NOTE: January – June 2011 data is unaudited. With each successive period, new data will be added until six 6-month periods are displayed.

**NC = None Claimed.

ADDITIONAL DATA

METHOD OF DISTRIBUTION:

All qualified circulation conforms to the Field Served and Definition of Recipient Qualification, as reported. Print copies are distributed via postal services or other carriers. Recipients who request the digital versions are notified via email when the version is available.

STATEMENT OF CONTENT PLATFORM

Replica - Editorial and design are unchanged from the original print edition.

PARAGRAPH 3b:

Communication other than Request includes 4 sources of circulation from a low of 45 copies or 0.1% to a high of 2,953 copies or 8.4%.

1. AVERAGE QUALIFIED CIRCULATION BREAKOUT FOR PERIOD – PRINT VERSION ONLY

QUALIFIED CIRCULATION	Total Qualified		Qualified Non-Paid		Qualified Paid	
	Copies	Percent	Copies	Percent	Copies	Percent
Individual	29,112	100.0	29,112	100.0	-	-
Sponsored Individually Addressed	-	-	-	-	-	-
Membership Benefit	-	-	-	-	-	-
Multi-Copy Same Addressee	-	-	-	-	-	-
Single Copy Sales	-	-	-	-	-	-
TOTAL QUALIFIED CIRCULATION	29,112	100.0	29,112	100.0	-	-

1. AVERAGE QUALIFIED CIRCULATION BREAKOUT FOR PERIOD – DIGITAL VERSION ONLY

QUALIFIED CIRCULATION	Total Qualified		Qualified Non-Paid		Qualified Paid	
	Copies	Percent	Copies	Percent	Copies	Percent
Individual	5,717	100.0	5,717	100.0	-	-
Sponsored Individually Addressed	-	-	-	-	-	-
Membership Benefit	-	-	-	-	-	-
Multi-Copy Same Addressee	-	-	-	-	-	-
Single Copy Sales	-	-	-	-	-	-
TOTAL QUALIFIED CIRCULATION	5,717	100.0	5,717	100.0	-	-

PUBLISHER'S AFFIDAVIT

We hereby make oath and say that all data set forth in this statement are true.

Bill Rodman, Associate Publisher

Debbie Brady, Audience Development Manager

(At least one of the above signatures must be that of an officer of the publishing company or its authorized representative.)

IMPORTANT NOTE:

This unaudited circulation statement has been checked against the previous audit report. It will be included in the annual audit made by BPA Worldwide.

Date signed July 13, 2011

State Ohio

County Cuyahoga

Received by BPA Worldwide July 13, 2011

Type PD

ID Number M397Y0J1